



Test Report

Contract No : 10040604B-2

Issue Date : Apr. 16 , 2010

Applicant : U-MOUTH ENTERPRISE CO., LTD

Address: No.553-1 Sec. 3Li-Ming Rd,407 Taichung,Taiwan
R.O.C.

Product : Wheel assembly

Model No : HCWS

Test Method : CPSC : 2004 Requirement for bicycles. Sec.
1512.11 (c) Rim Test

財團法人
自行車暨
健康科技
工業研究
發展中心

- Note: (1)The product is supplied by the applicant which has been tested by CHC and the test result is shown in this test report.
- (2)This test report is responsible only for the tested product, not for the suit.
- (3)This test report has 4 pages which shall not be abstracted and partial copied.
- (4)There is only one test report for the applicant.

Approved by : *James Sun*

Tested by : *Gavin Lin*

FORM NO : RI 20-02



1. Test item : Static test for wheel assembly.
2. Test standard : CPSC : 2004 Requirement for bicycles. Sec. 1512.11

(c) Rim Test.

3. Test equipment: Universal Test machine(A1).
4. Test method and requirement :
 - 4.1 Clamp and support around the wheel suitably and apply a static force of 2,000 N at the wheel axle are shown in Fig. A.
 - 4.2 Apply the force once only for a duration of 30 sec.
 - 4.3 After testing, there shall be no failure of any of the components of the wheel, and still rotated smoothly.
 - 4.4 The wheel assembly shall be aligned such that no less than 1.6 mm clearance exists between the tire and fork or any frame member when the wheel is rotated to any position.

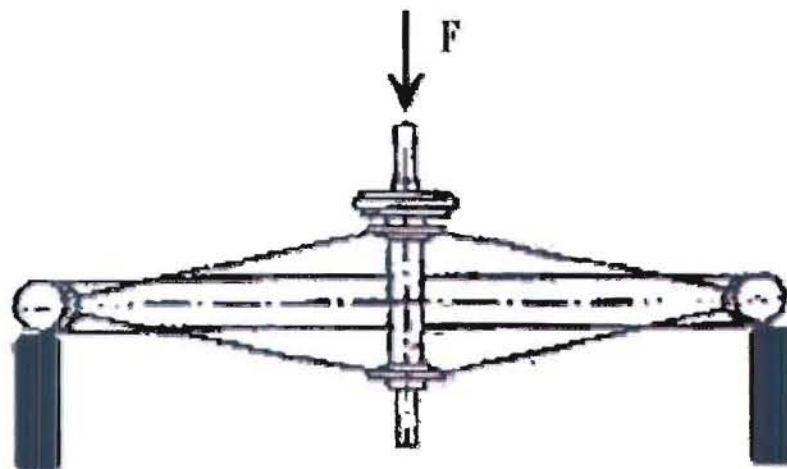

Fig. A Static test for wheel assembly

5. Test result :

5.1 Test sample : As shown in Fig. 1, before the test, function is normal.



Fig. 1 Test sample

5.2 The condition after the test :

The tested wheel assembly has no cracks and visual fracture, and the wheel still rotated smoothly. The permanent deformation of the tested wheel axle is 13.11mm. Appears in the middle of two plastic pieces 0.9mm gap. The test shown in Figure 2~3 .



Fig. 2 Static test for wheel assembly